



Installation Manual

Electric Fan Controller Kit

PFE-HC7110BK / PFE-HC7111BK

Included Items	QTY
Fan Control Module	1
Harness with Push in Probe OR Thermostat	1
Blue Butt Connectors	2
Blue 5/16" Ring Terminal	1
Blue #10 Ring Terminal	1
Blue Wire Tap Connector	1
Red Butt Connector	1
12 Gauge Red Wire	1
4" Wire Ties	4

WARNING: PLEASE READ ALL INSTRUCTIONS BEFORE PROCEEDING. PROFLOW WILL NOT BE RESPONSIBLE FOR ANY DAMAGE AS A RESULT OF THE INCORRECT INSTALLATION OF THIS PRODUCT. IT IS RECOMMENDED THAT A QUALIFIED AUTOMOTIVE TECHNICIAN PERFORMS THIS INSTALLATION.

Control Module Installation

1. Choose an appropriate location to mount the relay. Preferred location will be near the battery and where the thermostat will be located. Do not mount next to high heat sources such as near exhaust housings, etc.
2. Use the modules mounting surface as a template to find and mark the mounting holes. Drill 4x 5/32" holes in the correct locations.
3. Use the supplied screws to secure the unit.

Thermostat Installation

Thread-in Thermostat

1. Locate a 3/8" NPT port either on the radiator, water neck, intake manifold or cylinder head.
2. Using teflon tape, thread the 3/8" thermostat into the desired location.

Probe Thermostat

1. The thermostat probe must be inserted into the core of the radiator. The best location for the probe will be near the inlet of the radiator, in between the fins.
2. The probe should be secured tightly in between the radiator fins (full width of radiator).

Wiring

1. Before starting, disconnect the negative terminal on the battery.
2. Red (loose wire): positive battery to positive fan lead.
3. Red (w/fuse): negative fan lead.
4. Black wire: Chassis ground.
5. White wire: Ignition power.
6. Green wire: A/C override circuit. The green wire is designed to work in two different configurations. When used, this will allow the fan(s) to be turned on when the A/C is being used (regardless of temperature). This overrides all other functions.
 - (a) Using the blue wire tap provided, attach the green wire to the positive lead on the air conditioning compressor.
 - (b) Manual switch override: attach the green wire to the manual switch (not included) with a positive feed.

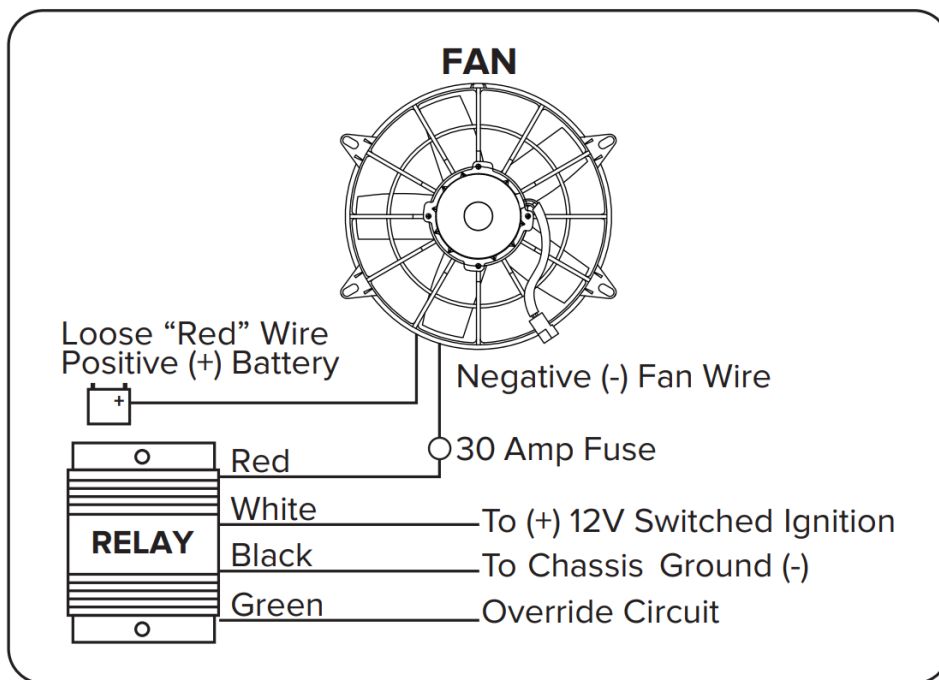

Figure 1: Wiring diagram

Temperature Adjustment

1. Remove the rubber plug.
2. Turn adjustment screw counter clockwise to lower the starting temperature.
3. Turn adjustment screw clock wise to raise the starting temperature.
4. Reinstall the rubber plug.
5. Ensure all loose wires and fittings are secured and tightened. Start the car and wait until the fan turns on. If it does not, turn the adjustment screw counter clockwise in small increments until the fan starts.