

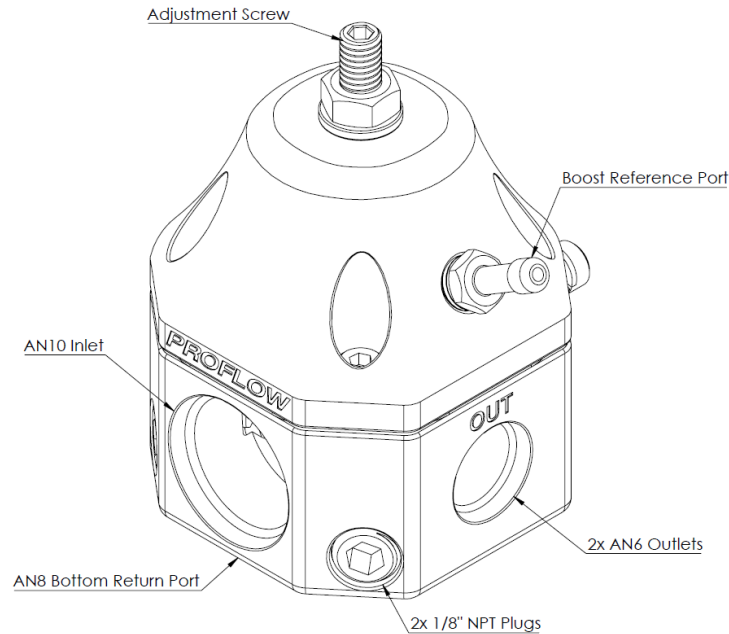

Installation Manual

Carburettor Bypass Fuel Pressure Regulator

PFEFS13204



Included Items	QTY
PFEFS13204 Fuel Pressure Regulator	1
PFE932-04BK Socket Plug 1/8" NPT	2
PFE358 1/16" NPT to 5/32" Barb	1
PFEFS13204 Mounting Bracket and Screws	1

WARNING: PLEASE READ ALL INSTRUCTIONS BEFORE PROCEEDING. PROFLOW WILL NOT BE RESPONSIBLE FOR ANY DAMAGE AS A RESULT OF THE INCORRECT INSTALLATION OF THIS PRODUCT. IT IS RECOMMENDED THAT A QUALIFIED AUTOMOTIVE TECHNICIAN PERFORMS THIS INSTALLATION.

WARNING: THE INSTALLATION OF THIS PRODUCT REQUIRES THE HANDLING OF FUEL. IT IS RECOMMENDED TO WORK IN A WELL-VENTILATED AREA AND WEAR APPROPRIATE PERSONAL PROTECTION. KEEP ALL IGNITION SOURCES AND FLAMES AWAY FROM THE VEHICLE AT ALL TIMES. DO NOT OPEN THE FUEL SYSTEM UNTIL THE PRESSURE HAS BEEN RELIEVED.

Description

This Proflow regulator utilizes one o-ring sealed AN10 ORB style inlet port, two o-ring sealed AN6 ORB outlet ports and one o-ring sealed AN8 ORB return port. These ports are not pipe thread and require no thread sealant. To use the enclosed regulator in your vehicles fuel system, you must install the necessary adapter fittings and o-rings, fuel lines and/or fuel rails to adapt your fuel system to the configuration and ports of this fuel pressure regulator.

PROFLOW.COM.AU

EMAIL: sales@proflow.com.au
PHONE: 1300 879 879

Typical Installation

1. Once the engine has been allowed to cool, disconnect the negative battery cable and relieve the fuel system pressure. Refer to your vehicles manual to do this.
2. Remove the old fuel pressure regulator and remove its vacuum line (some vehicles do not have vacuum operated regulators).
3. Place a container around the regulator to catch any fuel that is spilled during the removal of the old regulator.
4. Mount the regulator in a suitable place in the vehicles engine bay using the supplied mounting bracket and self tapping screws, or an equivalent safe method (other brackets may be used if necessary).
5. Attach the fuel supply line to the -10AN inlet port on the front of the regulator using AN ORB style fittings and o-rings. Attach the carburetter's supply lines to the -06AN outlet ports. Install the appropriate -06AN plug if only one outlet is being used.
6. Attach the fuel return line to the regulators bottom port using an -08AN ORB style fitting.
7. Make sure to tighten all connections to prevent any leaks before adjusting the fuel pressure.
8. Once the regulator is installed, attach a suitable fuel pressure gauge to one of the 1/8" NPT ports on the fuel pressure regulator (PFEEFG15BK). Use thread sealant when installing the fuel pressure gauge and ensure the other port is blocked.
9. Ensure that the area around the engine bay is free from any fuel including under and around the vehicle.
10. Reconnect the battery and turn the ignition to the on position without starting the car. After several seconds, check the fuel pressure. If there is no fuel pressure, turn the ignition key to the OFF position, wait one minute, return the ignition to the ON position, and recheck the fuel pressure. Repeat this ignition OFF and ON procedure until the fuel pressure gauge registers fuel pressure.
11. Once the fuel pressure gauge registers fuel pressure and there are no fuel leaks, start the engine and adjust the regulator to the desired fuel pressure. Turning the adjustment screw CLOCKWISE will increase fuel pressure. The fuel pressure adjustment range for the enclosed regulator is 4-13 PSI.
12. Once the desired fuel pressure is achieved, tighten the regulator adjustment jam nut and attach the vacuum line if the vehicle has one. If the vehicle is not equipped with a vacuum line, leave this vacuum port open to atmosphere. Blocking the vacuum port will yield poor regulator performance.
13. If you do not want to keep the fuel pressure gauge on the vehicle, relieve the fuel system pressure as instructed in the appropriate vehicle service manual. Remove the fuel pressure gauge and reinstall the 1/8" NPT plug into the regulator gauge port, using thread sealant.