



PFEFS13220 Carburettor Regulator

WARNING : THE FUEL SYSTEM IS UNDER PRESSURE. DO NOT OPEN THE FUEL SYSTEM UNTIL THE PRESSURE HAS BEEN RELIEVED. REFER TO THE APPROPRIATE VEHICLE SERVICE MANUAL FOR THE PROCEDURE AND PRECAUTIONS FOR RELIEVING THE FUEL SYSTEM PRESSURE. INSTALLATION OF THIS PRODUCT REQUIRES DETAILED KNOWLEDGE OF AUTOMOTIVE SYSTEMS AND REPAIR PROCEDURES. WE RECOMMEND THAT THIS INSTALLATION BE CARRIED OUT BY A QUALIFIED AUTOMOTIVE TECHNICIAN. INSTALLATION OF THIS PRODUCT REQUIRES HANDLING OF FUEL. ENSURE YOU ARE WORKING IN A WELL VENTILATED AREA WITH AN APPROVED FIRE EXTINGUISHER NEARBY. WHEN INSTALLING THIS PRODUCT, WEAR EYE PROTECTION AND HAVE OTHER SAFETY EQUIPMENT AS NEEDED TO PROTECT YOURSELF.

PLEASE MAKE SURE ALL THE INSTRUCTIONS ARE READ PRIOR TO INSTALLATION

This Proflow regulator utilizes one o-ring sealed AN06 style inlet port and two o-ring sealed AN06 style outlet ports. These regulator ports are NOT PIPE THREAD and utilize NO THREAD SEALANT. To use the enclosed regulator in your vehicle's fuel system, you must install the necessary adapter fittings and o-rings, and other fuel supply equipment in order to accommodate for this regulator.

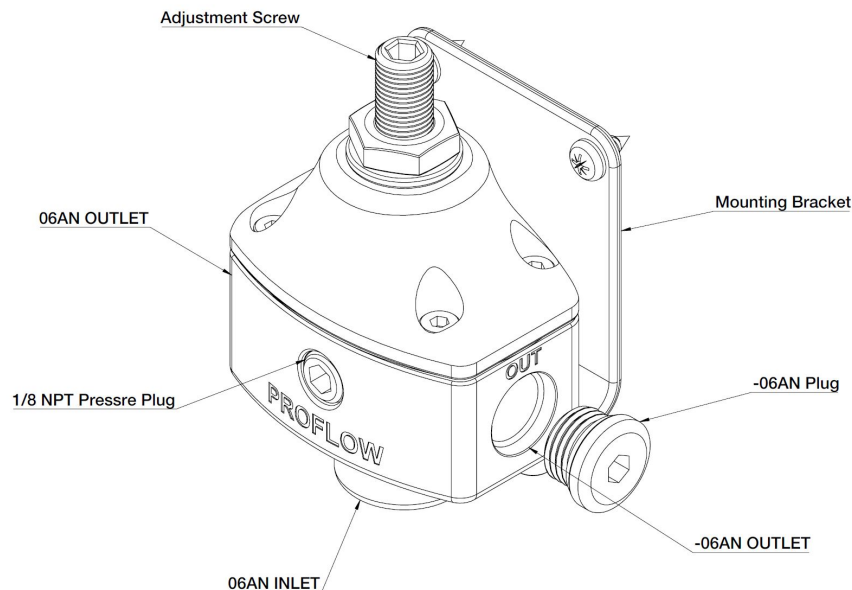

The following steps are typical of most installations:

- 1). Once the engine has been allowed to cool, disconnect the negative battery cable and relieve the fuel system pressure.
- 2). Remove the old fuel pressure regulator.
- 3). Remove the vacuum line from the regulator (some vehicles do not have vacuum operated regulators).
- 4). Place container around the regulator to catch any fuel that is spilled during the removal of the old regulator.

- 5). Mount the regulator in a suitable place in the vehicle's engine compartment using the supplied mounting bracket.
- 6). With the bracket attached to the regulator, mount the bracket and regulator to the vehicle using the two screws supplied (or other methods).
- 7). Attach the fuel outlet line(s) to the regulator outlet side ports using AN fittings and O-rings. If only one fuel outline line is used, install the supplied 06AN style plug and o-ring into the second regulator outlet port.
- 8). Attach the fuel Inlet line to the regulator bottom port using an AN-06 style fitting and o-ring.
- 9). Make sure to tighten all connections.
- 10). Once the regulator is installed, attach a suitable fuel pressure gauge to the 1/8 NPT port on the fuel pressure regulator. (0-15psi fuel pressure gauge, part # PFEFG015). Use thread sealant when installing fuel pressure gauge.
- 11). Ensure that the area around the engine bay is free from any spilled fuel. This includes under the vehicle.
- 12). Reconnect the battery and turn the ignition to the ON position WITHOUT starting the car. After several seconds, check the fuel pressure. If there is no fuel pressure, turn the ignition key to the OFF position, wait one minute, return the ignition to the ON position, and recheck the fuel pressure. Repeat this ignition OFF and ON procedure until the fuel pressure gauge registers fuel pressure.
- 13). With the fuel pressure gauge registering fuel system pressure, check for fuel leaks from and around the regulator and all fuel lines and connections near the regulator! If any fuel leaks are found, turn the ignition key to the OFF position, remove any spilled fuel and repair the leak before proceeding!
- 14). Once the fuel pressure gauge registers fuel system pressure and there are no fuel leaks, start the engine and adjust the regulator to the desired fuel pressure. Turning the adjustment screw clockwise will increase fuel pressure. The fuel pressure adjustment range for the enclosed regulator is 5-12 psi.
- 15). Once the desired fuel pressure is achieved, tighten the regulator adjustment jam nut and attach the vacuum line if the vehicle has one. If the vehicle is not equipped with a vacuum line, leave vacuum port open to atmosphere. Blocking the vacuum port will yield poor regulator performance.
- 16). If you do not want to keep the fuel pressure gauge on the vehicle, relieve the fuel system pressure as instructed in the appropriate vehicle service manual. Remove the fuel pressure gauge and reinstall the 1/8 NPT pipe plug into the regulator gauge port, using thread sealant.

PROFLOW LIMITED WARRANTY

This Proflow Product is warranted to be free from defects in materials and workmanship for a period of one year from the original date of purchase. No warranty claim will be valid without authentic, dated proof of purchase. This warranty is to the original retail purchaser and none other and is available directly from Proflow and not through any point of distribution or purchase. If a defect is suspected, the retail purchaser must contact Proflow directly to discuss the problem, possible solutions and obtain a Return Goods

Authorization (RGA), if deemed necessary by the company. All returns must be shipped freight pre-paid to the company and with valid RGA before they will be processed. Any product returned with the proper authorization to determine if the failure resulted from a defect or from abuse, improper installation or alteration. Proflow will then, at its sole discretion, return, repair or replace the product. This warranty is limited and expressly limits any implied warranty to one year from the date of the original retail purchase on all Proflow products.

No person, party or corporate entity other than Proflow shall have the right to: determine whether or not this Limited Warranty is applicable to any Proflow product, authorize any action whatsoever under the terms and conditions of this Limited Warranty, assume any obligation or liability of any nature whatsoever on behalf of Proflow under the terms and conditions of this Limited Warranty.