



INSTALLATION MANUAL

Air/Fuel Ratio Gauge

PFEGA-1005

Included Items	QTY
Wideband Air/Fuel Ratio Gauge	1
Controller & Harnesses	1
Bosch Sensor	1
Weld In Bung	1

WARNING: PLEASE READ ALL INSTRUCTIONS BEFORE PROCEEDING. PROFLOW WILL NOT BE RESPONSIBLE FOR ANY DAMAGE AS A RESULT OF THE INCORRECT INSTALLATION OF THIS PRODUCT. IT IS RECOMMENDED THAT A QUALIFIED AUTOMOTIVE TECHNICIAN PERFORMS THIS INSTALLATION.

TYPICAL INSTALLATION

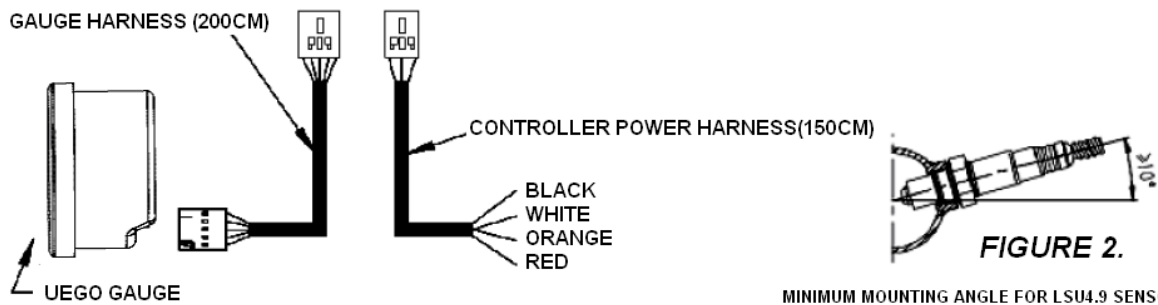
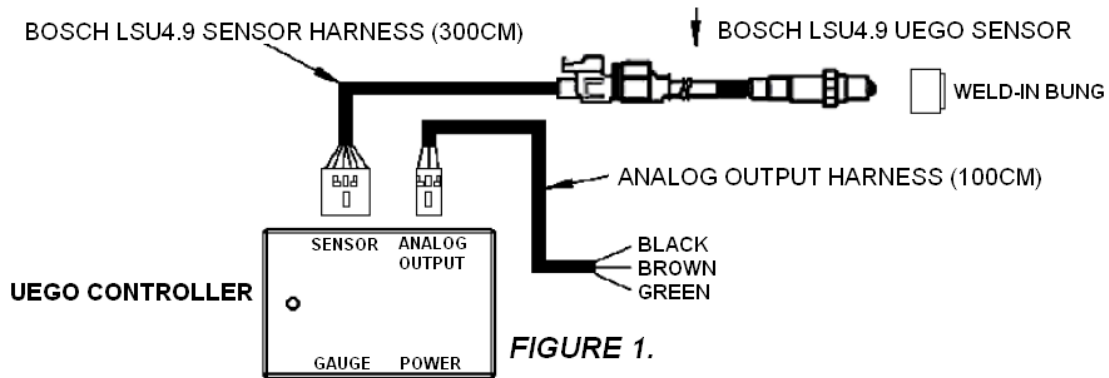

- RED:** 12V Accessory Power (+)
- WHITE:** Engine Accessory Power (+)
- BLACK:** Engine Ground (-)
- ORANGE:** Connect to Headlight Switch 12V (+)

A weld-in M18 x 1.5 boss is supplied for sensor installation. Mount the O2 sensor in the exhaust system at least 18" downstream from the exhaust port. If you anticipate high EGT's (over 800°C), run a turbocharger, run at high RPM for extended periods of time, or plan on running leaded race fuel, then you must mount the sensor at least 36" or more downstream of the exhaust port as all of these can cause the sensor to overheat. On turbocharged engines the UGEO sensor must be installed after the turbocharger, if not the pressure differential will greatly effect the accuracy of the unit. For accurate readings, the sensor must be mounted before catalytic converters and/or auxiliary air pumps. To prevent collection of liquids between the sensor housing and sensor element during the cold start phase, the installation angle should be inclined at least 10° from horizontal with the electrical connection upwards, see above (Figure 2).

VOLT	LAMBDA	GASOLINE AFR
0.00	0.683	10.00
0.16	0.705	10.32
0.31	0.725	10.62
0.47	0.747	10.94
0.62	0.768	11.24
0.78	0.790	11.56
0.94	0.811	11.8
1.09	0.832	12.18
1.25	0.854	12.50
1.40	0.874	12.80
1.56	0.896	13.12
1.72	0.918	13.44
1.87	0.939	13.74
2.03	0.960	14.06
2.18	0.981	14.36
2.34	1.003	14.68
2.50	1.025	15.00
2.65	1.045	15.30
2.81	1.067	15.62
2.96	1.087	15.92
3.12	1.109	16.24
3.28	1.130	16.54
3.43	1.152	16.86
3.59	1.173	17.18
3.74	1.194	17.48
3.90	1.216	17.80
4.06	1.236	18.10
4.21	1.258	18.42
4.37	1.280	18.74
4.52	1.301	19.04
4.68	1.322	19.36
4.84	1.343	19.66
4.99	1.356	19.98

Calibration Mode

Press the button on the controller for 3 seconds to calibrate the controller. When the LED screen displays [2] the controller is calibrating.

Sensor Error Diagnosis

When the LED screen displays [3] it is a sensor error code. Please check if the sensor is disconnected or defective.

Original Manufacture Setting Mode

Press the button on the controller for 8 seconds to operate the original manufacture setting of the controller. The LED screen will display [2] first. After the LED screen displays [4] the original manufacture setting is programmed.

Analog Output Wire Harness Instruction

BLACK: Engine Ground

BROWN: Wide band analog output 0-5V (0V → 10AFR, 5V → 20AFR)

GREEN: Narrow band analog output 0-1V (0V → 20AFR, 1V → 10AFR)

Bosch LSU 4.9 Wideband O2 Sensor

Please Read Carefully

The wideband gauge (excluding sensor, sensor wire and bolt, and weld-in bung) comes with a one year warranty from the date of purchase (if goods fail and failure is not caused by improper operation).

This gauge is sold for racing use only and there is no warranty attached or implied on the Bosch 4.9 sensor. All sales and purchases are made on this basis.

Proflow & Bosch are free from responsibility and liability in the event of a malfunction of the Bosch 4.9 sensor.